



GT2005i POWER INVERTER GENERATOR

2000W



Please ensure that you read this manual in full before using your machine and follow the maintenance and operation instructions carefully.

OPERATING INSTRUCTIONS



We Appreciate Your Business.

Thank you and congratulations for choosing GT Power. You have invested in a machine that will last a lifetime if you follow strictly the maintenance and care guidelines set out in this manual.

This Operating Manual has been designed to instruct you on the correct use and operation of your GT Power product. Your satisfaction with this product and its safe operation is our ultimate concern. Therefore please take the time to read the entire manual, especially the Safety Precautions. They will help you to avoid potential hazards that may exist when working with this product.

WARNING!

READ AND UNDERSTAND ALL SAFETY PRECAUTIONS IN THIS MANUAL BEFORE OPERATING. FAILURE TO COMPLY WITH INSTRUCTIONS IN THIS MANUAL COULD RESULT IN PERSONAL INJURY, PROPERTY DAMAGE, AND/ OR VOIDING OF YOUR WARRANTY. GT POWER WILL NOT BE LIABLE FOR ANY DAMAGE BECAUSE OF FAILURE TO FOLLOW THESE INSTRUCTIONS.

Table Of Contents

Symbol Usage	4
General Safety Precautions	4
Generator Controls & Features	10
Specifications.....	10
Control Panel	11
Control Functions	12
Getting Started	14
Wattage Reference Guide	17
Calculating Your power Needs	18
Electrical Connection.....	18
Maintenance	20
Storage	25
Troubleshooting	27
Warranty.....	28

Symbol Usage

This manual contains important information that you need to know and understand in order to assure YOUR SAFETY and PROPER OPERATION OF EQUIPMENT. The following symbols help you recognize this information. Please read the manual and pay attention to these sections. Save These Important Safety Instructions! Read and understand all of these safety instructions. Be sure to retain them for future use.



WARNING!

Warnings indicate a certainty or strong possibility of personal injury or death if instructions are not followed.



CAUTION!

Cautions indicate a possibility of equipment damage if instructions are not followed properly.

NOTE:

Notes give helpful information.

Gasoline powered and electrical generating products can cause serious injury or death, or damage to other equipment or property, if the operator does not strictly observe all safety rules and take precautionary actions.

General Safety Precautions

Carbon Monoxide

- Carbon Monoxide is an odourless and colourless gas. Breathing exhaust that contains this poisonous gas can cause unconsciousness and may lead to death.
- The engine exhaust from this product contains chemicals known to cause cancer, birth defects, or other reproductive harm.
- When this tool is running, ensure that the area is well ventilated. Never run the engine in an enclosed area. Run the engine in an open area or with an exhaust evacuation system in an enclosed area.
- NEVER use a generator inside homes, garages, crawlspaces, or other partially enclosed areas. Deadly levels of carbon monoxide can build up in these areas. Using a fan or opening windows and doors does NOT supply enough fresh air.
- ONLY use a generator outdoors and far away from open windows, doors, and vents. These openings can pull in generator exhaust.
- Even when you use a generator correctly, CO may leak into the home. ALWAYS use a battery-powered or battery-backup CO alarm in the home.
- If you start to feel sick, dizzy, or weak after the generator has been running, move to fresh air RIGHT AWAY. See a doctor. You could have carbon monoxide poisoning.



WARNING!

The exhaust contains poisonous carbon monoxide gas that can cause loss of consciousness and may lead to death.

Gasoline and Oil

This product requires oil and fuel. THE ENGINE WILL NOT START WITHOUT OIL. Work in well-ventilated area. Keep cigarettes, flames or sparks away from the work area or where gasoline is stored.



WARNING!

Gasoline is extremely flammable and is explosive under certain conditions. Keep out of reach of children.

- Gasoline fuel and fumes are flammable and potentially explosive. Use proper fuel storage and handling procedures. Always have multiple ABC class fire extinguishers nearby.
- Keep the generator and surrounding area clean at all times.
- Keep the generator at least 5 feet away from buildings and other equipment during operation.
- Fuel or oil spills must be cleaned up immediately. Dispose of fluids and cleaning materials as per any local, state, or federal codes and regulations. Store oily rags in a covered metal container.
- Never store fuel or other flammable materials near the generator.
- Do not smoke, or allow sparks, flames or other sources of ignition around the engine and fuel tank. Fuel vapours are explosive.
- Keep earthed conductive objects, such as tools, away from exposed, live electrical parts and connections to avoid sparking or arcing. These events could ignite fumes or vapours.
- Do not refill the fuel tank while the engine is running or while the engine is still hot. Do not operate the generator with known leaks in the fuel system.
- Excessive build-up of unburned fuel gases in the exhaust system can create a potentially explosive condition. This build-up can occur after repeated failed start attempts, valve testing, or hot engine shutdown.
- Use only engine manufacturer recommended fuel and oil.

Hot Components



WARNING!

Hot exhaust can burn you. Engine and exhaust system parts become very hot and remain hot for some time after the engine is run. Wear insulated gloves or wait until the engine and exhaust system have cooled before handling these parts.

Work Area

- Keep your work area clean and well lit. Cluttered benches and dark areas invite accidents.
- Do not operate power tools in explosive atmospheres, such as in the presence of flammable liquids, gases, or dust. Generators create sparks which may ignite the dust or fumes.
- Keep bystanders, children, and visitors away while operating a generator. Provide barriers or shields as needed.

Electrical Safety

- Keep all electrical equipment clean and dry. Replace any wiring where the insulation is cracked, cut eroded part or otherwise degraded. Replace terminals that are worn, discoloured, or corroded. Keep terminals clean and tight.

- Insulate all connections and disconnected wires.
- Do not abuse the power cord. Keep power cords away from heat, oil, sharp edges, or moving parts. Replace damaged power cords immediately. Damaged power cords increase the risk of electric shock.
- Do not operate the generator with wet hands. Do not expose generator to rain, snow or wet conditions. Water will increase the risk of electric shock. The generator is a potential source of electrical shock if not kept dry.
- Do not attempt to connect or disconnect load connections while standing in water, or on wet or soggy ground.
- Do not touch electrically energized parts of the generator and interconnecting cables or conductors with any part of the body, or with any non-insulated conductive object.
- Avoid body contact with earthed surfaces such as pipes, radiators, ranges, and refrigerators. There is an increased risk of electric shock if your body is earthed.
- When operating a power tool outside, use a premium quality outdoor extension cord. These extension cords are rated for outdoor use, and reduce the risk of electric shock.
- Earthed tools must be plugged into an outlet properly installed and earthed in accordance with all codes and ordinances. Never remove the earth prong or modify the plug in any way. Do not use any adapter plugs.
- Double insulated tools are equipped with a polarized plug where one blade is wider than the other. This plug fits in a polarized outlet only one way. If the plug does not fit fully in the outlet, reverse the plug. If it still does not fit, contact a qualified electrician to install a polarized outlet. Do not change the plug in any way. Double insulation eliminates the need for the three-wire earthed power cord and earthed power supply system.
- Before servicing equipment powered by the generator, disconnect the equipment from its power input.
- The generator must be earthed for fixed installations in accordance with all relevant electrical codes and standards before operation.
- Earthing provides a low-resistance path to carry electricity away from the user in the event of an electrical malfunction.
- All connections and conduits from the generator to the load must only be installed by trained and licensed electricians and in compliance with all relevant local, state, and federal electrical codes and standards, and other regulations where applicable.
- Connect the generator only to a load or electrical system (230 volt) that is compatible with the electrical characteristics and rated capacities of the generator.
- NEVER try to power building or home wiring by plugging the generator into a wall outlet, a practice known as “backfeeding.” This is extremely dangerous and presents an electrocution risk to utility workers and neighbours served by the same utility transformer. It also bypasses some of the built-in household circuit protection devices.

Personal Safety



WARNING!

Do not sit, stand, or place objects on top of the generator regardless of whether it is running or not.

- Stay alert. Watch what you are doing, and use common sense when operating a generator. Do not use generator while tired or under the influence of drugs, alcohol, or medication. A moment of inattention while operating generators may result in serious personal injury.
- Make note of the location of the engine power switch should you need to turn off the generator quickly.
- Dress properly. Contain long hair, clothing, jewellery, and gloves as they can be caught in moving parts.
- Avoid accidental starting. Make sure the power switch is in its "OFF" position, and disconnect the spark plug wire when not in use.
- Remove adjusting keys or wrenches before turning the generator on. A wrench or a key that is left attached to a rotating part of the generator may result in personal injury.
- Do not overreach. Keep proper footing and balance at all times.
- Use safety equipment. Always wear eye protection. Wear AS/NZS approved safety impact eye goggles. Dust mask, non-skid safety shoes, safety gloves, hard hat, or hearing protection must be used for appropriate conditions.
- Do not use the generator if the power switch does not turn it on or off. Any generator that cannot be controlled with the power switch is dangerous and must be repaired.

- Do not force the generator. Use the correct generator for your application. The correct generator will do the job better and safer at the rate for which it is designed.

Generator Use and Care

- Make sure the power switch is in its "OFF" position and disconnect the spark plug wire before making any adjustment, changing accessories, or storing the generator. Such preventive safety measures reduce the risk of starting the generator accidentally.
- Store idle generators out of reach of children and other untrained persons. Generators are dangerous in the hands of untrained users.
- Maintain generators with care. Do not use a damaged generator.
- Tag damaged generators "Do not use" until repaired.
- Check for misalignment or binding of moving parts, breakage of parts, and any other condition that may affect the generator's operation. If damaged, have the generator serviced before using. Many accidents are caused by poorly maintained generators.
- Use only accessories that are recommended by the manufacturer for your model. Accessories that may be suitable for one generator may become hazardous when used on another generator.

Servicing

- Maintain labels and name plates on the generator and engine. These carry important information. If unreadable or missing, contact your GT Power agent immediately for a replacement.

- Generator service must be performed only by qualified repair personnel. Service or maintenance performed by unqualified personnel could result in a risk of injury.
- When servicing a generator, use only genuine replacement parts. Follow all appropriate instructions in this manual. Use of unauthorized parts or failure to follow maintenance instructions may create a risk of electric shock or injury.

**WARNING!**

People with pacemakers should consult their physician(s) before using this product. Electromagnetic fields in close proximity to a heart pacemaker could cause interference to or failure of the pacemaker.

Installation

- Ensure installation meets all applicable safety, and local and national electrical codes. Have installation performed by a qualified, licensed electrician and building contractor.
- All electrical work, including the earth connection, should be completed by a licensed electrician.
- Any separate fuel storage or generator supply facility must be built or installed in full compliance with all relevant local, state, and federal regulations.
- It is recommended to use the generator only in well ventilated outdoor areas. A running gasoline engine will generate carbon monoxide, a colourless, odourless gas that, if inhaled, can cause serious injury or death. If the generator is installed indoors, exhaust fumes must be piped out of the building using leak-free, heat resistant piping. Pipes and silencer should not use any flammable materials, nor

should they be installed near the same. Generator exhaust fumes must be within legal limits and installation must always meet local building codes.

- If the generator is installed outdoors, it must be weatherproofed and should be soundproofed. It should not be run outdoors without protection of the generator and wiring conduit.
- The supporting floor/ground surface should be level, and strong enough to safely hold the weight of the generator.

Mechanical

- Always make sure the power switch is in its "OFF" position.
- Disconnect the spark plug wire, and allow the engine to completely cool before carrying out maintenance.
- Check for damaged parts. Before using the generator, any part that appears damaged should be carefully checked to determine that it will operate properly and perform its intended function. Check for alignment and binding of moving parts, any broken parts or mounting fixtures, and any other condition that may affect proper operation technician.
- The generator is designed with guards for protection from moving parts. In any case, care must still be taken to protect personnel and equipment from other mechanical hazards when working around the generator.
- Do not operate the generator with safety guards removed. While the generator is running, do not attempt to reach around the safety guard for maintenance or any other reason.
- Keep hands, arms, long hair, loose clothing, and jewellery away from moving

parts. Be aware that when engine parts are moving fast they cannot be seen clearly.

- Keep access doors on enclosures closed and locked when access is not required.
- When working on or around the generator always wear protective clothing including AS/NZS approved safety gloves, safety eye goggles, and safety hat.
- Do not alter or adjust any part of the generator that is assembled and supplied by the manufacturer.
- Always follow and complete scheduled engine and generator maintenance.

Chemicals

- Avoid contact with hot fuel, oil, exhaust fumes, and hot solid surfaces.
- Avoid body contact with fuels, oils and lubricants used in the generator. If swallowed, seek medical treatment immediately. Do not induce vomiting if fuel is swallowed. For skin contact, immediately wash with soap and water. For eye contact, immediately flush eyes with clean water and seek medical attention.

Noise

Prolonged exposure to noise levels above 85dBA is hazardous to hearing. Always wear AS/NZS approved ear protection when operating or working around the Generator when it is running.

Extension Cords

If an extension cord (not included) is used, make sure to use only AS/NZS approved cords having the correct gauge and length according to the following table:

Output Load (W)	Cord Lengths	
	15m	15-30m
0-700	1.5mm ²	2.5mm ²
700-1000	1.5mm ²	2.5mm ²
1000-1300	2.5mm ²	2.5mm ²
1300-1600	2.5mm ²	2.5mm ²
1600-1800	2.5mm ²	2.5mm ²

Generator Controls & Features

1. Exhaust and Spark Arrestor
2. Carrying handle
3. Vented Gas Cap
4. Recoil Starter Rope
5. Control Panel
6. 230V Power Outlet

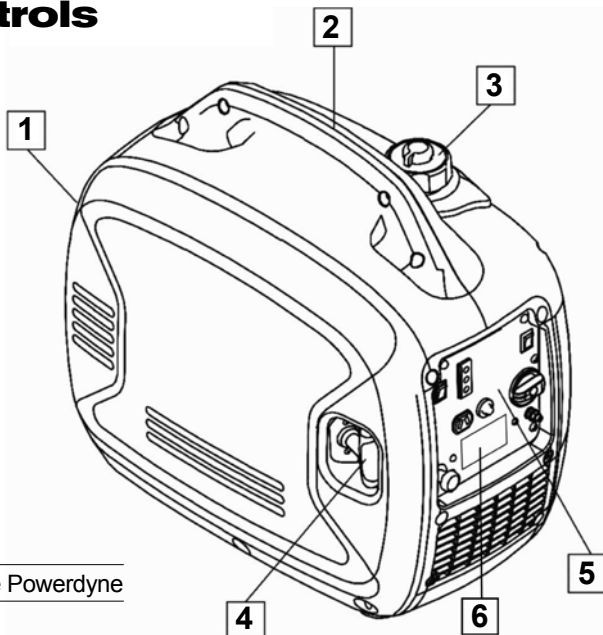

Specifications

Engine Type:	4-Stroke Powerdyne
Engine Displacement:	79CC
Running Watts:	1600w
Starting Watts:	2000w
Rated Frequency:	50HZ
Rated Voltage:	230V
Rated Current:	7A
Run Time:	10.5hrs at 1/4 load
Receptacles (qty.):	(2) 230V AC; (1) 12V 8A DC
Net Weight:	20kg
Noise Level:	51dB @ 1/4 Load
Fuel Type:	Unleaded gasoline
Fuel Capacity:	4 Litres
Oil Type:	SAE 10W-30
Start Type:	Recoil
L x W x H:	500 x 280 x 450mm
Rated Parallel Watts:	3200W
Max Parallel Watts:	3400W

Control Panel

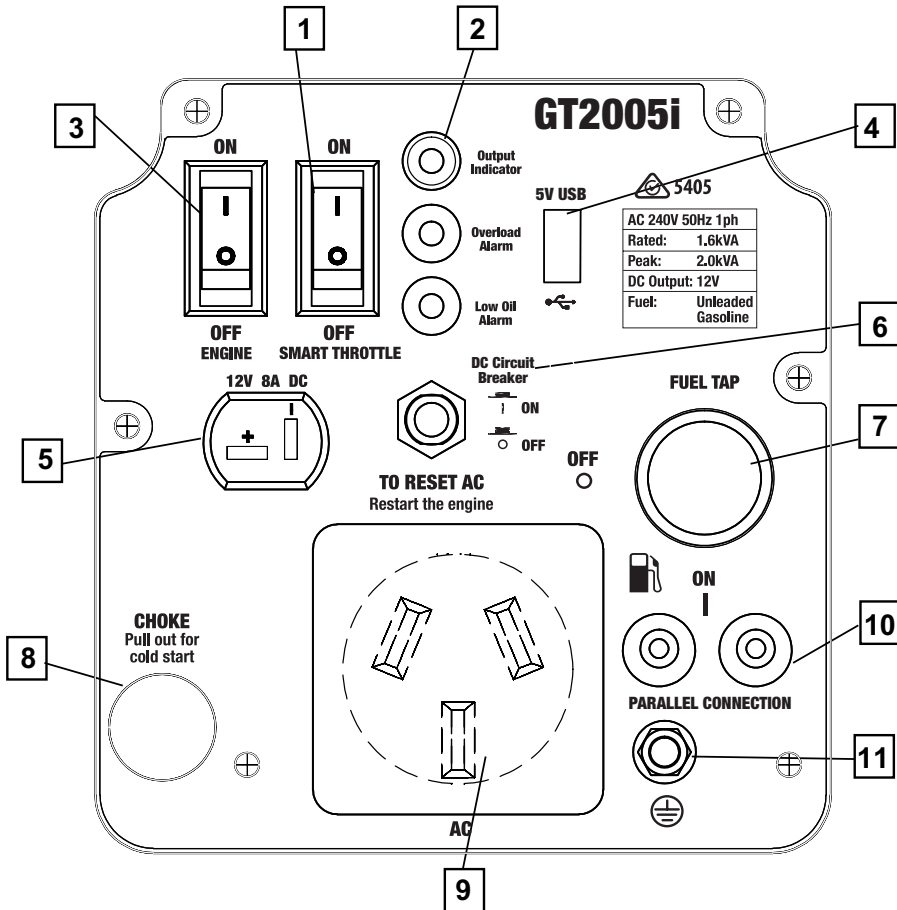

- | | |
|--------------------------|-------------------------|
| 1. Smart Throttle Switch | 7. Fuel Tap |
| 2. LED Indicators | 8. Choke |
| 3. Engine Switch | 9. 230V AC Outlet |
| 4. USB Charging Port | 10. Parallel Connection |
| 5. 12V DC Output | 11. Earth Connector |
| 6. 8A DC Circuit Breaker | |

Control Functions

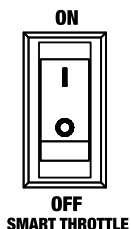

Smart Throttle

When the Smart Throttle switch is in the “ON” position the smart throttle controls the engine speed according to the connected electrical load. The results are better fuel consumption and less noise.

When the switch is in the “OFF” position the engine runs at 4,500 rpm regardless of the electrical load.

NOTE: The Smart Throttle must be “OFF” when using electrical devices that require a large starting current, such as a compressor, pump, or refrigerator.

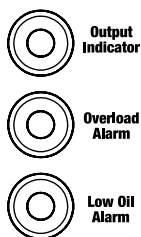

LED Indicators

The LED Indicators assist in communicating proper and improper functions of the unit.

Output Indicator (Green)

The LED Indicators assist in communicating proper and improper functions of the unit.

Overload Alarm (Red)

The Overload Alarm comes on when a connected device requires more power than the generator is able to produce, the inverter control unit overheats, or the AC output voltage rises above rated values. The Output Indicator (Green) will go off and the Overload Alarm (Red) will stay on, but the engine will continue to run.

When the Overload Alarm light comes on and power generation stops, proceed as follows:

1. Turn off any connected electric devices and stop the engine.
2. Reduce the total wattage of connected electric devices within the rated output.
3. Check for blockages in the cooling air inlet and around the control unit. If any blockages are found remove them.
4. After checking, restart the engine.

NOTE: The Overload Alarm may come on for a few seconds when first using electrical devices that require a large starting current, such as a compressor, pump, or refrigerator. This is normal behaviour it is not a malfunction.

Low Oil Alarm (Red)

When the engine oil falls below the required level the Low Oil Alarm will come on and the engine will stop automatically. The engine will not restart until oil is added to the unit to bring it up to the appropriate level.

NOTE!

When starting the unit, if the Low Oil Alarm light flickers and the engine will not start, you will need to add engine oil before attempting to restart the engine.



CAUTION!

Generator should only be operated on a level surface. DO NOT operate the generator on loose ground or obvious inclines. The low oil shutdown feature may be prematurely activated in these cases causing the engine to not start.

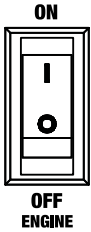

Engine Switch

The Engine Switch controls the ignition switch. The switch must be in the “ON” position to start the generator. Switching to the “OFF” position stops the engine and will not allow the engine to be restarted.

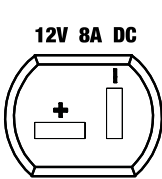

12V 8A DC

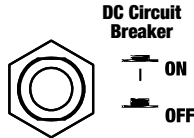

DC Circuit Breaker

TO RESET AC
Restart the engine

12V 8A DC Outlet

The 12V 8A DC Outlet is provided for battery charging. Follow instructions on page 25 in the owner’s manual for the battery charging procedures.

8A DC Circuit Breaker

The 8A DC Circuit Breaker turns off automatically if the current exceeds 8A. If the circuit breaker turns “OFF” you will need to push it “in” to turn it “ON” again

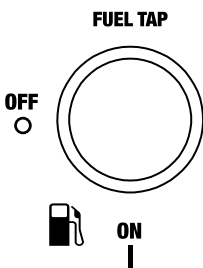

FUEL TAP

Fuel Tap

The Fuel Tap controls the flow of gasoline from the fuel tank to the carburettor. The Tap knob should be in the “ON” position when starting and operating the generator. The Tap knob should be in the “OFF” position when the engine is not running and when storing or transporting the unit.

knob should be in the “OFF” position when the engine is not running and when storing or transporting the unit.

NOTE: The Fuel Tap knob helps to prevent stale fuel from remaining in the carburettor while storing or transporting the unit. Run the fuel out by turning the knob to the “OFF” position and letting the engine run until it stops.

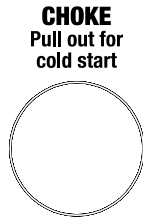

Choke

The Choke is used when starting the engine “cold” (the engine is not hot). Pull out fully on the choke when starting the engine. Once the engine has warmed and a steady idle is achieved, push in on the choke.

NOTE: When restarting a warm engine the choke is not necessary.

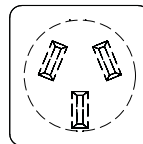

230V AC Outlet

The Outlet is used to power 230V Single Phase 50Hz loads requiring up to 1600W continuous power.

AC



Earth

The Earth terminal is used to earth the generator when earthed electrical devices are being used. Consult an electrician for local earthing regulations.

5V USB

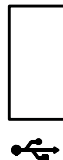

USB Outlet

The USB outlet is used to power and charge anything with a USB plug, such as phones, media players and other 5V DC devices.

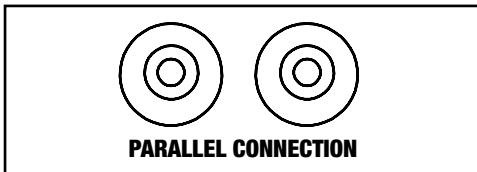

Parallel Connection

The parallel connection is a feature that allows two GT2005i machines to be connected together almost doubling the output of one unit. Check your wattage reference guide and be sure the device you are connecting is less than the rated use of this generator in parallel use (see specifications). Follow instructions in the owner's manual for the parallel connection procedure.

Getting Started

Unpack the Generator

Remove the generator from its packaging.

WARNING!
*Packaging is flammable!
Do not attempt to add fuel to this unit
before removing it from packaging.*

Inspect the generator to ensure that no damage has occurred in shipping or handling. If the unit appears to be damaged, DO NOT add fuel or attempt to start the generator. Please call GT Power Customer Service on 0800 387 678 (NZ) or 1800 040 947 (AUS).

Check to ensure that you received the following items:

- GT2005i 2000W Generator
- 12V Charging Cables
- 400ml Oil
- Oil Funnel

If any items are missing please contact GT Power Customer Service on 0800 387 678 (NZ) or 1800 040 947 (AUS).

Adding Engine Oil

CAUTION!
The generator has been shipped without engine oil. DO NOT ADD FUEL or start the engine before adding engine oil.

In order to add motor oil you will need to remove the side panel from the unit.

Using a #2 Phillips-head screwdriver remove screws (1) and (2), as seen in figure 1, and lift up and away to remove the side panel.

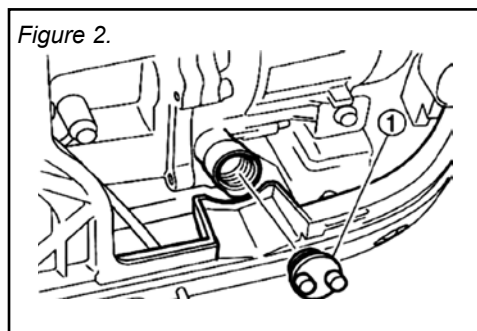
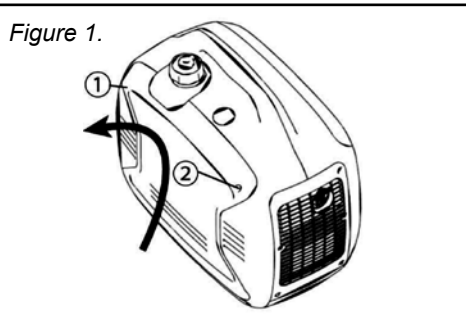

Place the generator on a level surface. DO NOT tilt the generator while adding oil. It can cause you to overfill the oil and/or cause the oil to leak into areas in which it is not intended.

Remove the oil filler cap (1), as seen in figure 2.

Figure 3.

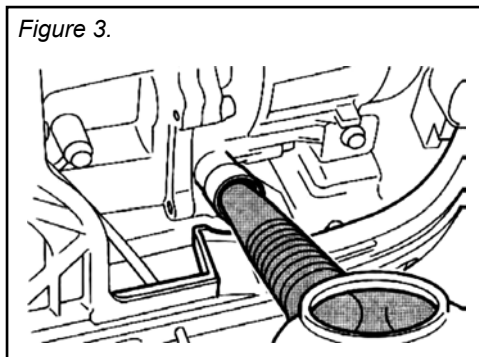

Using the funnel (provided) fill with 0.4L of SAE 10W-30 or 10W-40 (provided) (see figure 3). See figure 4 for proper oil level (1).

Replace oil filler cap and secure side panel with screws.

Figure 4.

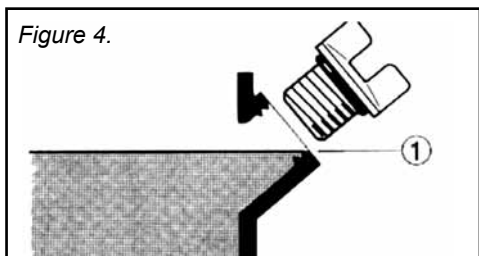

Recommended Engine Oil:

- A. SAE10W-30 or 10W-40
- B. SAE #30
- C. SAE#20
- D. SAE#10W

Recommended engine oil grade:

API Service SE type or higher engine oil quantity: 0.4L

Adding Fuel

The fuel tank holds 4 litres.

DO NOT overfill the tank, otherwise it may overflow when the fuel warms up and expands.

NOTE: For safety reasons, once fuel has been added to this unit it cannot be returned to the place of purchase.

1. Use clean, fresh, regular unleaded fuel with a minimum octane rating of 91.
2. DO NOT mix oil with fuel.
3. Clean area around the fuel cap.
4. Remove the fuel cap.
5. Be sure that the fuel strainer is in place.
6. Slowly add fuel to the tank. DO NOT overfill. Allow approximately ¼ inch of space for fuel expansion.
7. DO NOT fill above fuel strainer.
8. Screw on the fuel cap and wipe away and spilled fuel.

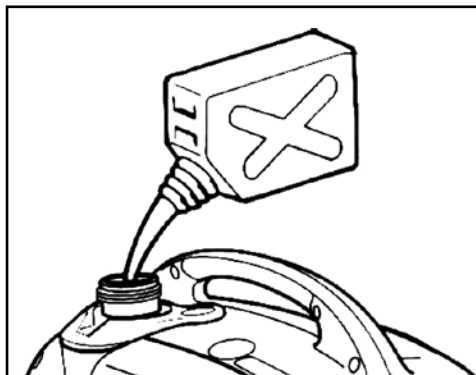

CAUTION!
 Use only unleaded gasoline. The use of leaded gasoline will cause severe damage to internal engine parts.

After filling with fuel, make sure the fuel tank cap is tightened securely.

Starting the Engine

WARNING!
 Operate the engine in a well ventilated area. Do not connect any electrical devices to the outlets on the generator before starting the engine.

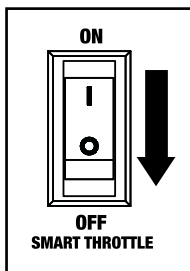

1. Turn the Smart Throttle switch "OFF".

You may turn the Smart Throttle switch to "ON" once the engine is started and a steady idle is achieved. (below 0°C 5mins, below 5°C 3mins.)

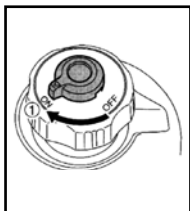

2. While holding the fuel tank cap so that it will not move, turn the air vent knob to "ON".

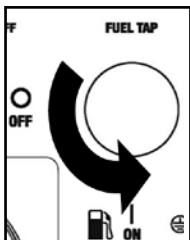

3. Turn the Fuel Tap knob to the "ON" position.

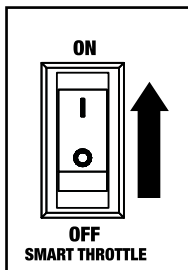

4. Turn the Engine Switch (Red) "ON"

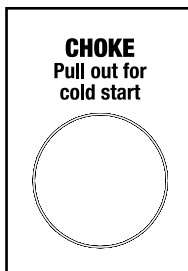

5. Pull the Choke Knob fully out.

NOTE: The Choke is not needed to start a warm engine. Push the knob in to the original position when starting the engine warm.

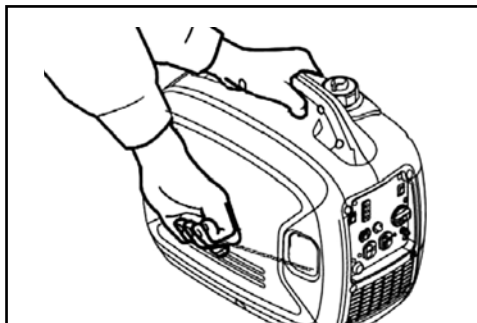

6. Grasp the carrying handle firmly to prevent the generator from falling over when pulling the recoil starter.

7. Pull slowly on the recoil starter until it is engaged and then pull it briskly.

8. After the engine starts, warm up the engine until the engine does not stop when the choke knob is returned the original position.

Stopping the Engine

Before stopping the engine turn off and disconnect any electronic devices attached to the generator.

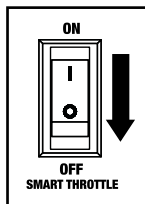

1. Turn the Smart Throttle switch to "OFF".

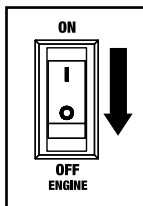

2. Turn the Engine Switch to "OFF".

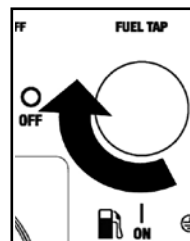

3. Turn the Fuel Tap to "OFF".

Wattage Reference Guide

Appliances	Approx Run (W)	Approx Start (W)	Appliances	Approx Run (W)	Approx Start (W)
Microwave 750W	750	1200	Central Air Conditioner:		
Coffee Maker	1750	1750	10,000 BTU	1500	2200
Electric Clothes Drier	5750	5750	24,000 BTU	3800	5000
Washing Machine	1150	2300	32,000 BTU	5000	6500
Refrigerator	700	2200	Room Air Conditioner		
Lights	100	100	10,000 BTU	1500	2200
Colour Television	350	350	Circular Saw 7 1/4"	1400	2300
Electric Frypan	1500	1500	Chainsaw 2HP	1100	2500
Dehumidifier	400	400	Portable Air Compressor	1200	3600
Computer - Desktop	700	700	Hand Drill 1/2"	600	900
VCR	50	50	Drill 1/2"	600	900
Dishwasher - Cool Dry	700	1400	Battery Charger - 15 amp	500	700
- Hot Dry	1450	2000	Electric Welder - 200 amp AC	9000	9000
Toaster - 2 Slice	1250	1250	Jigsaw	300	400
- 4 Slice	1600	1600	Electric Weed Trimmer	500	650
Freezer	2200	2500	Router	1000	1300
Hair Dryer	800-1700	800-1700	Belt Sander	1000	1300
Steam Iron	1800	1800	Table Saw 10"	1750	4250
Garage Door Opener - 1/4 HP	550	1100	Bench Grinder	1400	2450
- 1/3 HP	725	1400	Concrete Mixer 3.5c/f	1900	2500
Radio	200	200	Band Saw	1100	1350
Blender	375	500	Power Drill - Medium	1000	1200
Sump Pump 1/2 HP	1050	2150	- Heavy Duty	1500	1800
Well Pump 1/2 HP	1000	2100	Angle Grinder - 100mm	1000	1200
Household Water Pump	1200	2700	- 230mm	2400	2700

This chart lists average power requirements. Your particular tool or appliance may require more or less than the listed wattage. For exact wattages, check the data plate or owner's manual on the item you wish to power. Where START wattage

is the same as RUN wattage, this signifies no additional power is required for starting.

Total Running Watts + Highest Starting Watts = Generator Power Needs

Calculating Your Power Needs

1. Firstly list all items requiring power simultaneously.
2. Then add up all the “running wattage” requirements for all items.
3. Add to that total the highest of the “starting wattages” you listed down. Now you know approximately how much power you need to start and run your appliances and equipment.



CAUTION!

Operating voltage and frequency requirement of all electronic equipment should be checked prior to plugging them into this generator. Damage may result if the equipment is not designed

Tool or Appliance	Running Watts	Starting Watts
1.		
2.		
3.		
4.		
5.		
Total Running Watts		
Highest Starting Watts		

= Generator Power Needs

--

to operate within a +/- 10% voltage variation, and +/- 3 Hz frequency variation from the generator specification ratings.

Electrical Connection

Power Management

Use the following formula to convert voltage and amperage to watts:

$$\text{Volts} \times \text{Amps} = \text{Watts}$$

To prolong the life of your generator and attached devices, follow these steps to add electrical load:

1. Start the generator with no electrical load attached.
2. Allow the engine to run for several minutes to stabilize.
3. Plug in and turn on the first item. It is best to attach the item with the largest load first.
4. Allow the engine to stabilize.

5. Plug in and turn on the next item.
6. Allow the engine to stabilize.
7. Repeat steps 5-6 for each additional appliance or tool

Connecting Electrical Loads

1. Let the engine stabilize and warm up a few minutes after starting.
2. Prior to powering tools and equipment, make sure the generator’s rated voltage, and amperage capacity (230V AC 1600 watts continuous, 2000 watts peak) is adequate to supply all electrical loads that the unit will power. If powering exceeds the generator’s capacity, it may be necessary to group one or more of the

tools and/or equipment for connection to a separate generator.

3. Once the generator is running, simply connect the power cords of the 230 volt AC powered tools and equipment into the 230 volt AC outlet and/or the power cord of a 12V DC item to the DC terminals.
4. DO NOT connect 3-phase loads to the generator.
5. DO NOT overload the generator.



CAUTION!

The DC terminals may be used for charging 12 volt automotive type batteries only.

Battery Charging

Start the engine first and allow it to reach idle before connecting the generator to the battery. Battery Charging is performed using the 12V DC outlet only.

1. Be sure the Smart Throttle switch is turned "OFF" while charging batteries.
2. Be sure to connect the red battery charger lead to the positive (+) battery terminal, and connect the black lead to the negative (-) battery terminal. DO NOT reverse these positions.
3. Connect the battery charger leads to the battery terminals securely so that they are not disconnected due to engine vibration or other disturbances.
4. Charge the battery by following the instructions in the owner's manual for the battery.
5. The DC Circuit Breaker will turn "OFF" automatically if the current exceeds rated output.
6. To restart charging the battery, turn the DC protector on by pressing its button to "ON"

7. Refer to the owner's manual for the battery to determine charging times.

NOTE: *Never start or stop the generator with electrical devices plugged in or turned on.*

Parallel Connection

A maximum of 3400W can be drawn from a single outlet when in parallel connection mode.

Start the engine and allow it to reach idle before connecting any load to the generator.

1. Make sure the smart throttle is turned off while in parallel use
2. Connect the two parallel ports together (10) using the cables provided. Be sure to connect red to red and black to black.

CAUTION!



Incorrect connecting of the parallel cables can harm the generator. Any attempt to incorrectly link the GT2005i generators will result in the warranty of both generators becoming void.



3. Connect your appliance up to one of the two generators 15A outlets. Either one is suitable or both can be used if multiple loads are required.

NOTE: Be sure to check your appliance(s) draws less than the rated output of these generators in parallel use (see specs)

4. If multiple items are to be used see page 17 and 18 for more information.

5. A maximum of 15A can be drawn out of a single outlet. If maximum load is exceeded the red overload light will glow and the internal overload will turn off. This is a thermal type switch so some time is needed before the switch reactivates and the generator is ready to use again. Allow 5 - 10 minutes.

Maintenance

Item	Routine	Prior to use	Every 6mths or 100hrs	Every 12 mths or 300hrs
Spark Plug	Check condition Clean and replace if necessary	•		
Fuel	Check fuel level and leakage.	•		
Fuel hose	Check fuel hose for cracks or damage Replace if necessary.	•		
Engine oil	Check oil level in engine. Replace*	•	•*	
Air Filter Element	Check condition Clean		•	
Muffler Screen	Check Condition Clean or replace if necessary		•	
Spark Arrestor	Check Condition Clean or replace if necessary		•	
Fuel Filter	Check Condition Clean or replace if necessary			•

* Initial replacement of the engine oil is after one month or 20 hours of operation.

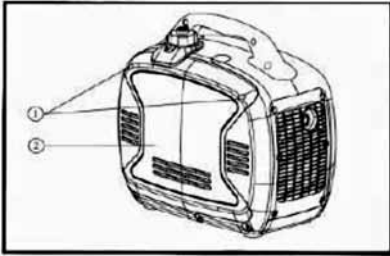

Spark Plug Maintenance

The spark plug is an important engine component and should be checked periodically.

1. Remove the screws (1) and then remove the cover (2).
2. Remove the spark plug cap (3) and access cap (4).
3. Insert the tool (5) through the hole in the outside of the cover.
4. Insert the handlebar (6) into the tool (5) and turn it counter clockwise to remove the spark plug.
5. Check for discoloration. The carbon porcelain insulator around the centre electrode of spark plug should be a Medium-to-light tan colour.
6. Check the spark plug type and gap. The spark plug gap should be measured with a wire thickness gauge and, if necessary, adjusted to specification.
7. Install spark plug, spark plug cap, cover and screws.

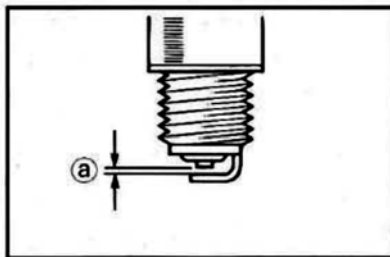
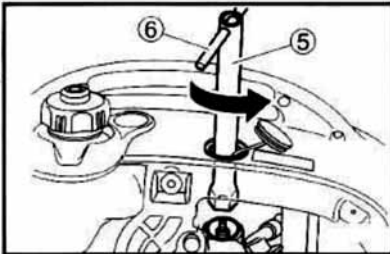
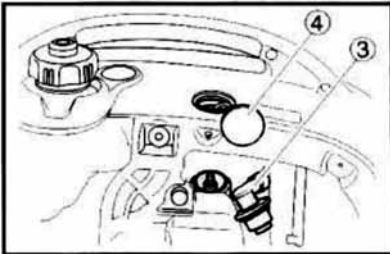

Spark Plug Type:

BPR6HS (NGK)

Spark Plug Gap: 0.6-0.7 mm (0.024-0.028 in)

Spark Plug Torque: 20.0 N·m (2.0kgf·m, 14.8 lbf·ft)

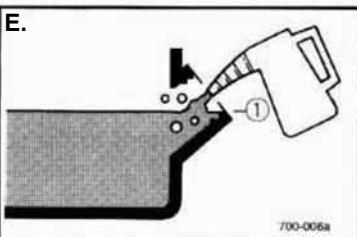
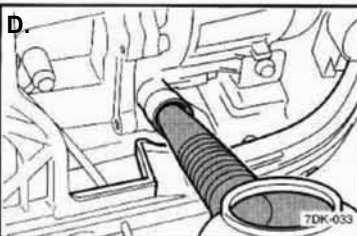
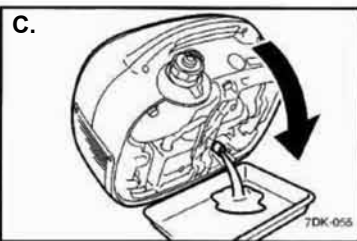
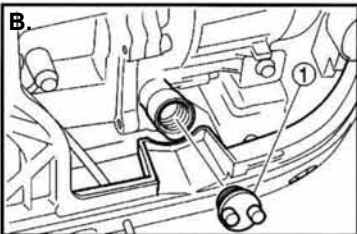
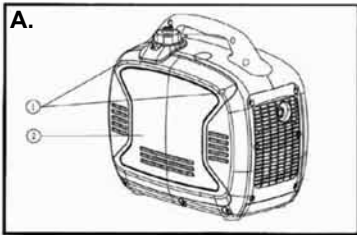

Engine Oil Replacement

Initial replacement of the engine oil is after one month or 20 hours of operation.

1. Place the generator on a level surface and warm up the engine for several minutes. Then stop the engine and turn the Fuel Tap knob to "OFF" and the Fuel Tank Cap Air Vent knob to "OFF".
2. (A) Remove the screws (1) and then remove the cover (2).
3. Remove the oil filler cap.
4. Place an oil pan under the engine. Tilt the generator to drain the oil completely.
5. Return the generator to a level surface.

⚠ CAUTION!
DO NOT tilt the generator when adding engine oil. This could result in overfilling and damage to the engine.

6. (B) Add engine oil to the upper level as seen in the diagram (1).

Recommended engine oil:

- SAE#30
- SAE#20
- SAE10W

Recommended engine oil grade:

API Service SE type or higher

Engine oil quantity:

0.4 Litre

7. Install oil filler cap, cover, and screws.

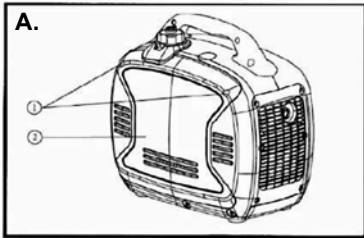

Air Filter Maintenance

Air filter maintenance should be performed every 6 months or 100 hours. The air filter may need to be cleaned more frequently when using in unusually wet or dusty areas.

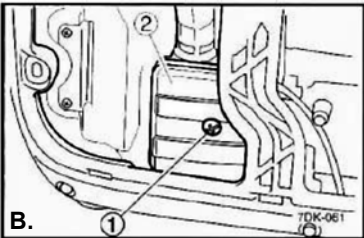

1. (A) Remove the screws (1) and then remove the cover (2).
2. (B) Remove the screws (1) and then remove the air filter case cover (2).

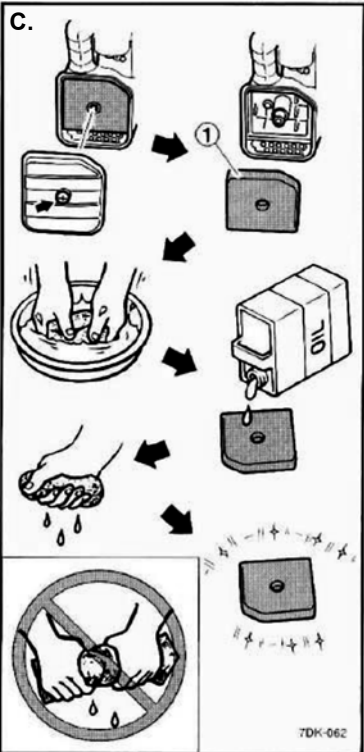

3. (C) Remove the foam element (1).
4. Wash the foam element in solvent and dry it.
5. Oil the foam element and squeeze out excess oil. The foam element should be wet but not dripping.

CAUTION!
Do not wring out the foam element when squeezing it. This could cause it to tear.

6. Insert the foam element into the air filter case. Be sure the foam element sealing surface matches the air filter so there is no air leak.

CAUTION!
The engine should never run without the foam element.

7. Install air filter case cover, cover, and screws.

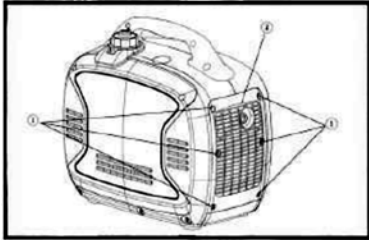

Muffler Screen and Spark Arrestor Maintenance

Should be performed every 6 months or 100 hours. The air filter may need to be cleaned more frequently when using in unusually wet or dusty areas.

1. (A) Remove the screws (1) and then remove the cover (2).
2. (B) Loosen the bolt (1) and then remove the muffler cap (2), the muffler screen (3) and spark arrester (D,4)
3. Remove the carbon deposits on the muffler screen and spark arrester using a wire brush. Use wire brush lightly to avoid damaging the muffler screen or spark arrester.
4. Check the muffler screen and spark arrester replace them if damaged.
5. Install the spark arrester.
6. Install the muffler cap.
7. Install the cover and tighten the screws.

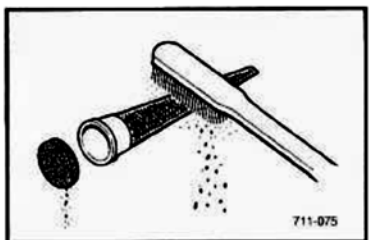
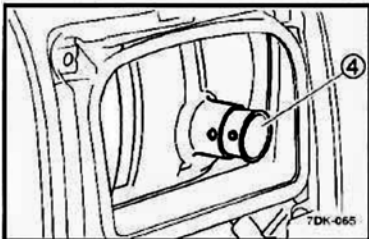
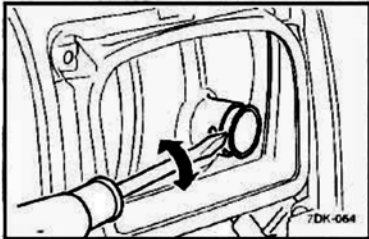
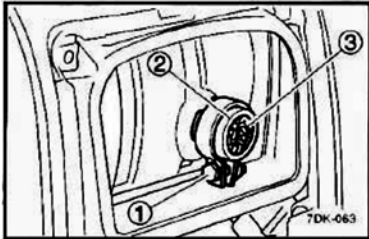

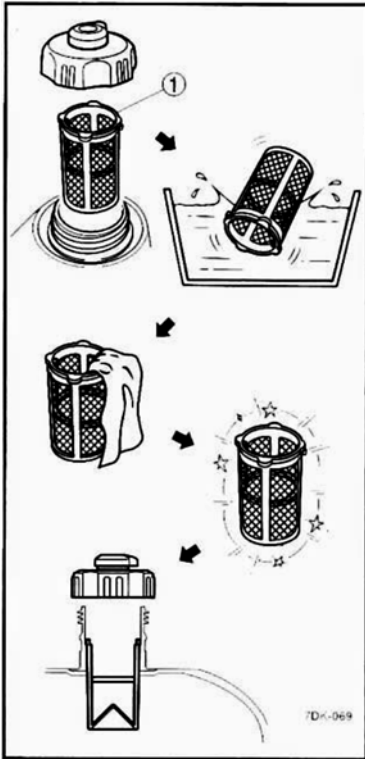

Fuel Filter Maintenance

Should be performed every 12 months or 300 hours.

1. Remove the fuel tank cap and filter (1).
2. Clean the filter with gasoline.
3. If damaged, replace it.
4. Wipe the filter and install it.
5. Install the fuel tank cap.



WARNING!

GASOLINE IS FLAMMABLE. DO NOT perform this maintenance while smoking or near an open flame.

Storage

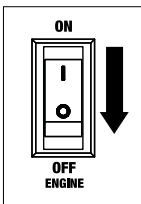

Long Term Storage

Long term storage of your machine will require some preventive procedures to guard against deterioration.

Drain the fuel

1. Turn Engine switch "OFF".
2. Remove the fuel tank cap. Extract the fuel tank into an approved gasoline container using a commercially available hand siphon. Then, install the fuel tank cap. Immediately wipe off spilled fuel with a clean, dry, soft cloth, since fuel may

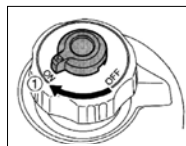
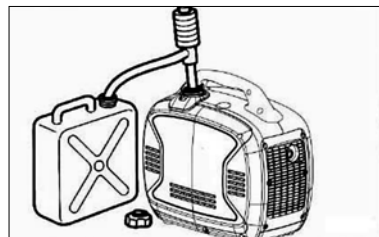

deteriorate painted surfaces or plastic parts.

3. Turn the Engine switch to "ON".

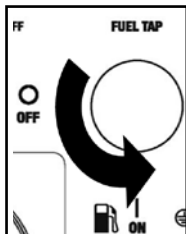

4. Turn the fuel tank cap air vent knob and Fuel Tap knob to "ON".

5. Start the engine and let it run until it stops.

Duration of the running engine depends on the amount of the fuel left in the tank.



WARNING!

GASOLINE IS FLAMMABLE. DO NOT perform this maintenance while smoking or near an open flame.

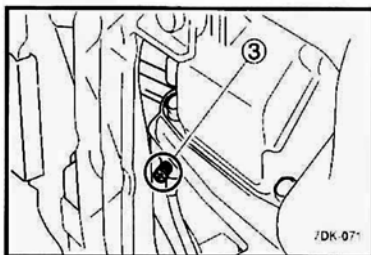
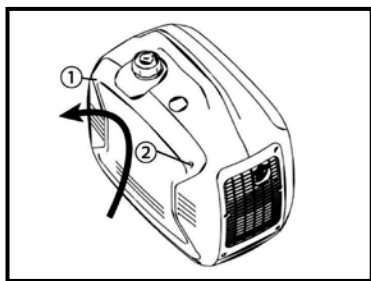

6. Remove the screws (1), and then remove the cover (2).

7. Drain the fuel from the carburettor by loosening the drain screw (3) on the carburettor float chamber.

8. Turn the Engine switch to "OFF"

9. Turn the fuel cock knob to "OFF"

10. Tighten the drain screw

11. Install the cover and tighten the screws.

12. Turn the fuel tank cap air vent knob to "OFF"

13. Store the generator in a dry, well-ventilated place, with the cover placed over it.

Engine

Perform the following steps to protect the cylinder, piston ring, etc. from corrosion.

1. Remove the spark plug, pour about one table-spoon of SAE 10W-30 or 20W-40 motor oil into the spark plug hole and reinstall the spark plug. Recoil start the engine by turning over several times (with ignition off) to coat the cylinder walls with oil.

2. Pull the recoil starter until you feel compression. Then stop pulling (this prevents the cylinder and valves from rusting).

3. Clean exterior of the generator and apply a rust inhibitor.

4. Store the generator in a dry, well-ventilated place, with the cover placed over it.

5. The generator must remain in a vertical position when stored, carried, or operated.

Troubleshooting

Engine Problems

PROBLEM (SYMPTOMS)	RECOMMENDED ACTION	IF PROBLEM PERSISTS
<p>Engine does not start</p>	<p>1. Turn engine switch to "ON", pull recoil starter.</p>	<p>If all recommended possible areas of misadjustment have been checked and the problem persists, contact your local GT Power Authorised Service Facility</p>
	<p>2. Check fuel. Fill if empty. See pg 15 for more information</p>	
	<p>3. If oil warning light flickers check oil level. If low, add engine oil. See pg 22 for more information.</p>	
	<p>4. Check sparkplug. (BPR6HS) Clean if necessary or adjust/replace gap. Gap: 0.6 - 0.7mm (0.024 - 0.028") See pg 21 for more information</p>	
	<p>5. Check fuel line, carburettor and air cleaner element for clogging. Clean if necessary. See pg 23 for more information.</p>	
<p>Generator won't produce power</p>	<p>1. Check safety device (DC protector) is "ON".</p>	
	<p>2. Turn safety device (AC) to "OFF". Stop engine and re-start.</p>	



Warranty

Serial Number: _____

Model: _____

Date Purchased: _____

Retailer Purchased Off: _____

Whilst every effort is made to ensure your complete satisfaction with this tool, occasionally, due to the mass manufacturing techniques, a tool may not live up to our required level of performance and you may need the assistance of our service department.

This product is warranted for a 12 month period from the date of the original purchase. If found to be defective in materials or workmanship, the tool or the offending faulty component will be replaced free of charge with another of the same item. A small freight charge may apply. Proof of purchase is essential.

We reserve the right to reject any claim where the purchase cannot be verified. This warranty does not include damage or defects to the tool caused by or resulting from abuse, accidents or alterations. It also does not cover any bonus items or included accessories. Only the generator is covered under this warranty.

Please ensure that you store your receipt in a safe place. Conditions apply to the above warranty.

The manufacturer warrants that it will repair or replace, at no charge for parts or labour, the GT POWER Generator, if proven defective in material or workmanship, during the following time period(s) after date of original retail purchase:

For 1 Year: The GT POWER GT2005i Inverter Generator (excluding accessories)

2. WHO GIVES THIS WARRANTY (Warrantor):

EUROQUIP NZ	EUROQUIP
NEW ZEALAND	AUSTRALIA
Service Line:	Service Line:
+ + 64 3 547 8409	1 - 800 040 947

3. WHO RECEIVES THIS WARRANTY (Purchaser):

The original purchaser of this GT POWER Inverter Generator

4. WHAT IS COVERED UNDER THIS WARRANTY:

Defects in material and workmanship which occur within the duration of the warranty period.

5. WHAT IS NOT COVERED UNDER THIS WARRANTY:

A. Implied warranties, including those of merchantability and FITNESS for a particular purpose are limited in duration to this express warranty. After this period, all risks of loss, from whatever reason, shall be on the purchaser.

B. ANY INCIDENTAL, INDIRECT, OR CONSEQUENTIAL LOSS, DAMAGE, OR EXPENSE THAT MAY RESULT FROM ANY DEFECT, FAILURE OR MALFUNCTION OF THIS PRODUCT.

C. This warranty does not apply to any accessory or consumable items included with the product which are subject to wear from usage; the repair or replacement of these items shall be at the expense of the owner. These items include, but are not limited to: sparkplugs, seals, o-rings, recoil starter parts, etc. In addition, this warranty does not extend to any damage caused by the untimely replacement or maintenance of any of the previously listed CONSUMABLE parts.

D. Any failure that results from accident, purchaser's abuse, neglect or failure to operate products in accordance with instructions provided in the owner's manual(s) supplied with the product.

E. Pre-delivery service, i.e. assembly and adjustment.

6. RESPONSIBILITIES OF WARRANTOR UNDER THIS WARRANTY: Repair or replace, at Warrantor's option, products or components which have failed within duration of the warranty period.

7. RESPONSIBILITIES OF PURCHASER UNDER THIS WARRANTY:

A. Please call your re-seller or the number listed above for warranty assistance.

B. Provide dated proof of purchase and maintenance records.

- C. All generators must be delivered or shipped to the nearest Service Agent or re-seller. Freight costs, if any, must be borne by the purchaser.
- D. Use reasonable care in the operation and maintenance of the products as described in the owner's manual(s).
- E. No warranty costs incurred will be considered for, or covered if Euroquip has not been contacted and prior permission for repair / replacement has been granted.

8. WHEN WARRANTOR WILL PERFORM REPAIR OR REPLACEMENT UNDER THIS WARRANTY:

Repair or replacement will be scheduled and serviced according to the normal work flow at the servicing location and depending on the availability of replacement parts.

Please attach your proof of purchase here.



Notes





Congratulations on your new GT POWER product. We are proud to have you as our customer and will strive to provide you with the best service and reliability in the industry. This product is backed by our extensive warranty and world-wide service network. To locate your nearest distributor or service agency call **0800 387 678**, or email us at info@euroquip.co.nz.